

RESEARCH ARTICLE

Gain scheduling linear model of an electro-hydraulic actuator

Cem Onat, Mahmut Daskin*, Abdullah Turan

Department of Mechanical Engineering, Inonu University, Turkey
cem.onat@inonu.edu.tr, mahmut.daskin@inonu.edu.tr, abduallah.turan@inonu.edu.tr

ARTICLE INFO

Article history:

Received: 13 June 2017

Accepted: 19 December 2017

Available Online: 19 December 2017

Keywords:

Nonlinear model

Electro-hydraulic system

Parameter varying

Gain scheduling

AMS Classification 2010:

34C99, 65P99, 60G99, 60J99

ABSTRACT

In different industrial processes in which position and force control are desired, electro-hydraulic systems have a widespread area of utilization. Models of electro-hydraulic systems include high order nonlinearity. In this study, a gain scheduling linear model corresponded with nonlinear model of a hydraulic force actuator system is developed. The proposed model is constituted in two distinct and consecutive stages. In the first step, nonlinear terms caused to nonlinearity are described by the means of measurable or observable system parameters and embedded in a nonlinear scheduling parameter. Thus, the scheduling parameter is continuously extracted from main system. In the second step, the nonlinear system equation is rearranged by the scheduling parameter and by this way parameter varying linear model is obtained. The simulations which are performed by use of Matlab-Simulink computer program show that the proposed model rightly fits to the nonlinear system model.



1. Introduction

Precision of position and force control of hydraulic systems is the key role of engineering applications in order to design more economical and quality systems. Because of their high force to weight ratio, small size and flexibility, facility of setting speed, force and torque, high precision control, etc., hydraulic systems are sufficient for many industrial areas such as manufacturing, aerospace industry, automotive technology and robotics [1–3]. The high control performance of the hydraulic systems has an importance as an engineering requirement, in order to create higher quality-systems and therefore computational modeling studies are important to obtain high level production quality. Furthermore, modeling and simulation studies have the potential to guide technological development and to reduce costs. However, highly nonlinear natures of electro-hydraulic servo systems are well-known. The nonlinearities of hydraulic servo systems have considerable effects on the model accuracy. They arise from compressibility of the hydraulic fluid, the complex flow properties of the servo-valve, and frictional forces [2]. In recent years,

significant improvements have been made on the modeling of hydraulic systems in the literature. Maneetham and Afzulpurkar [4] developed nonlinear mathematical models to obtain the experimental system responses. Pfeiffer [5] developed a new modeling scheme for hydraulic systems and illustrated the performance on a large industrial model. Deticek and Kastrevc [6] considered the nonlinear mathematical model of electro-hydraulic position servo system and, some simplifications of mathematical model according to specifications of real components. Eyres et al. [7] studied on several possible methods of modeling and dynamic response of a passive hydraulic damper with relief valve. A more complex nonlinear model incorporating the dynamics of the internal spring and fluid compressibility is obtained. Bonchis et al. [8] studied on the effect of friction nonlinearities on position control of hydraulic servo systems. Kalyoncu and Haydim [9] obtained a leakage in servo-valve and actuator. In hydraulic systems, cylinders are crucial component converting the fluid power into a linear motion and force. Cetin and Akkaya [10] obtained a mathematical model

*Corresponding author

of a hydraulically actuated system which was consisted of an asymmetric hydraulic cylinder rode by a four way, three position proportional valve. Interesting point of this model is that the bulk modulus parameter is considered as variable. Common point of the studies mentioned above is that it is obtained from nonlinear complex model, then it is synthesized nonlinear or complex controller. To remain within linear control theory and design a controller with high performance, it is a must to use a linear model corresponded with the nonlinear model. At this point, gain scheduling based modeling presents a powerful tool [11-18]. Gain scheduling is a widely used technique for modeling and controlling certain classes of linear or nonlinear time/parameter varying systems. Rather than seeking a linear time invariant (LTI) model or controller for the entire operating range, gain scheduling consists in modeling an LTI model or designing an LTI controller for each operating point and in switching model and controller when the operating conditions change [11, 12]. In this paper, a hydraulic force actuator is originally modelled by means of the gain scheduling technique. The obtained model completely fits to its nonlinear model. The proposed model is composed in two distinct and consecutive stages. Firstly, nonlinear terms which caused nonlinearity are described by measurable or observable system parameters and embedded in a nonlinear scheduling parameter. Thus, the scheduling parameter is continuously extracted from main system. Finally, the nonlinear system

equation is rearranged by means of the scheduling parameter and, parameter varying linear model is obtained. The simulations which are performed by using of Matlab-Simulink computer program show that the proposed model completely fits to the nonlinear system model. The rest of the paper is organized as follows. Nonlinear mathematical model of the hydraulic actuator with proposed gain scheduling model are presented in Sect. 2. In Sect. 3, numerical simulation results are considered. Finally, in Sect. 4, conclusions are presented in the light of simulation results.

2. Gain scheduling actuator model

A full set of a hydraulic force actuator compose of five main components named as piston-cylinder, electro hydraulic powered spool valve, hydraulic pump, reservoir and piping system. The hydraulic force actuators are governed by electro hydraulic servo valve allowing for the generation of forces between the sprung and un-sprung masses. As seen in Figure 1, the hydraulic actuator cylinder lies in a sequent configuration to a critically centered electro hydraulic power spool valve with matched and symmetric orifices. Positioning of the spool u directs high pressure fluid flow to either one of the cylinder chambers and connects the other chamber to the pump reservoir. This flow creates a pressure difference P_L across the piston. This pressure difference that multiplied by the piston area A_p is what provides the active force f . The system parameters are given in the Table1.

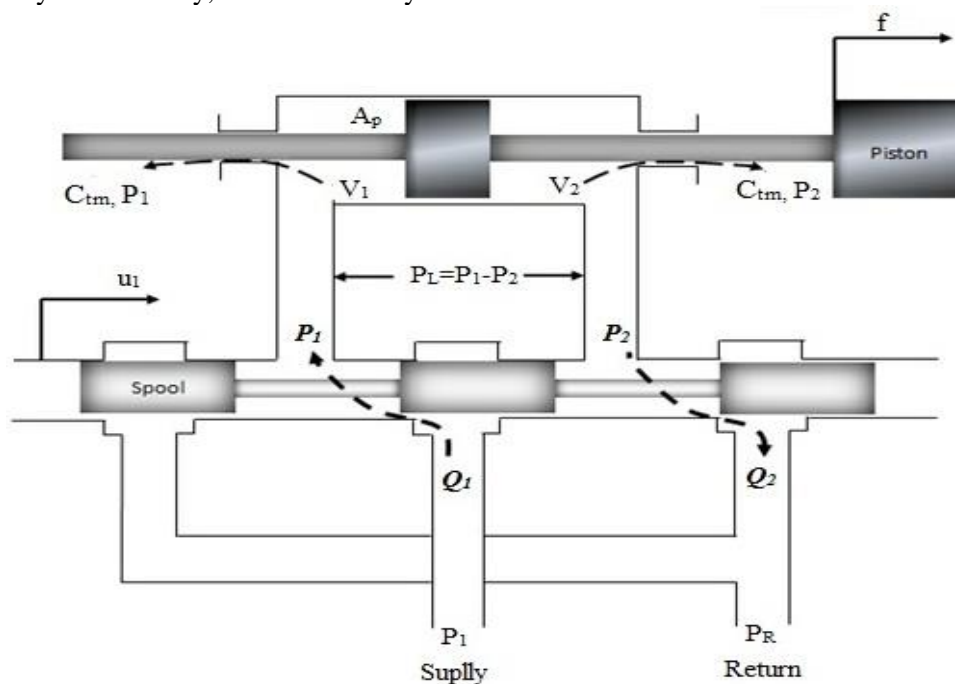

Figure 1. Physical schematic and variables for the hydraulic actuator.

Table 1. System parameters

A_p	Piston area	P_s	Supply pressure
α	Hydraulic factor	ρ	specific gravity of hydraulic liquid
C_d	Evacuation factor	C_{tm}	Leakage factor
$V_{1/2}$	volume of oil in chamber	P_L	Pressure difference
ω	Spool width	τ	Spool time constant
$P_{1/2}$	pressure in pipe 1 and 2	$Q_{1/2}$	flow in pipe 1 and 2

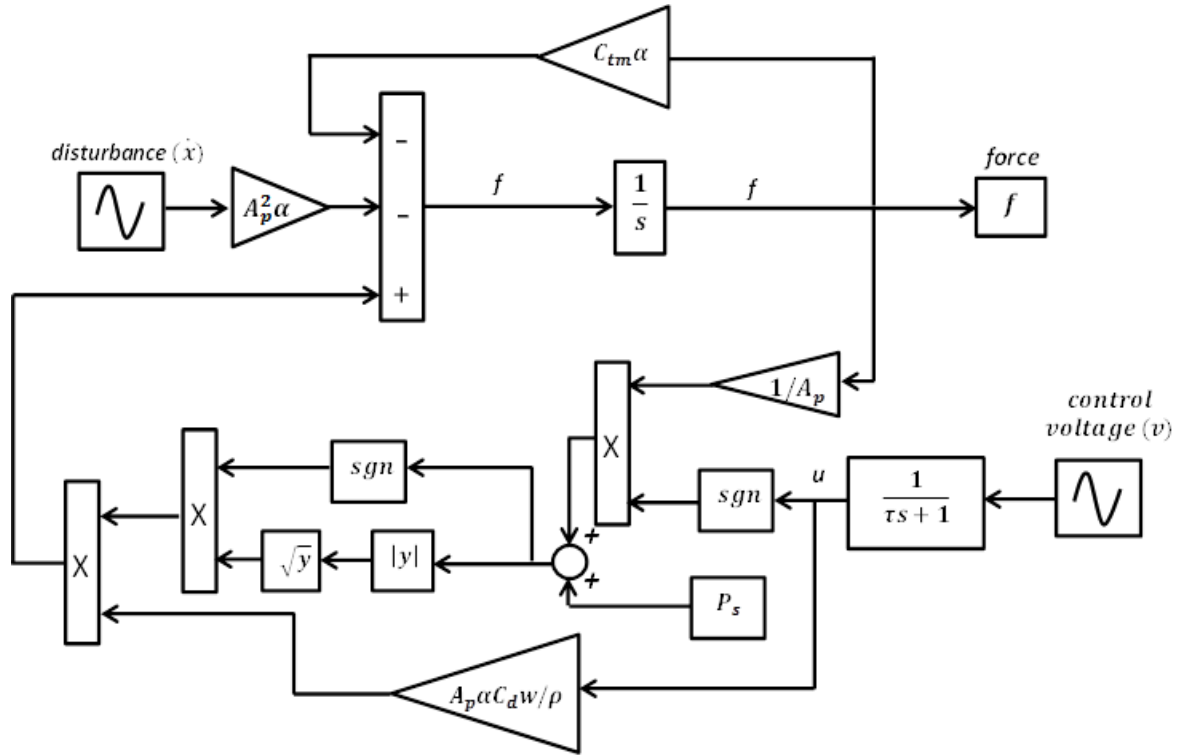

Figure 2. Matlab-Simulink block diagram of the nonlinear model.

$$\dot{f} = A_p \cdot \alpha \cdot [C_d \cdot \omega \cdot u \cdot \text{sgn}(\frac{P_s}{\rho} - \frac{\text{sgn}(u) \cdot f}{A_p}) \cdot \sqrt{|\frac{P_s}{\rho} - \frac{\text{sgn}(u) \cdot f}{A_p \cdot \rho}|} - C_{tm} \frac{f}{A_p} - A_p \cdot \dot{x}] \quad (1)$$

Nonlinear dynamics for the hydraulic actuator valve are given as the followings: the change in force is proportional to the position of the spool (u) with respect to center, the relative velocity of the piston ($\dot{x}_s - \dot{x}_u = \dot{x}$), and the leakage through the piston seals. Spool valve position u is controlled by a current-position feedback loop. The essential dynamics of the spool have been shown to resemble a first order system as the followings

$$\tau \cdot \dot{u} + u = k \cdot v \quad (2)$$

where, v is the control voltage. Matlab-Simulink

block diagram of the nonlinear hydraulic actuator model is given in Figure 2.

The scheduling parameter is defined in Equation 3.

$$C_x = \text{sgn}(\frac{P_s}{\rho} - \frac{\text{sgn}(u) \cdot f}{A_p \cdot \rho}) \cdot \sqrt{|\frac{P_s}{\rho} - \frac{\text{sgn}(u) \cdot f}{A_p}|} \quad (3)$$

If C_x is substituted in Eq. (1),

$$\dot{f} = A_p \cdot \alpha \cdot C_d \cdot \frac{u}{\sqrt{\rho}} \cdot C_x - C_{tm} \cdot \alpha \cdot f - A_p^2 \cdot \alpha \cdot \dot{x} \quad (4)$$

is obtained. Moreover, k , m and n expressions are

defined in Equations 5-7 respectively. The expressions are constants and derivable from system parameters.

$$k = A_p \cdot \alpha \cdot C_d \cdot \omega / \sqrt{\rho} \tag{5}$$

$$m = \alpha \cdot C_{tm} \tag{6}$$

$$n = A_p^2 \cdot \alpha \tag{7}$$

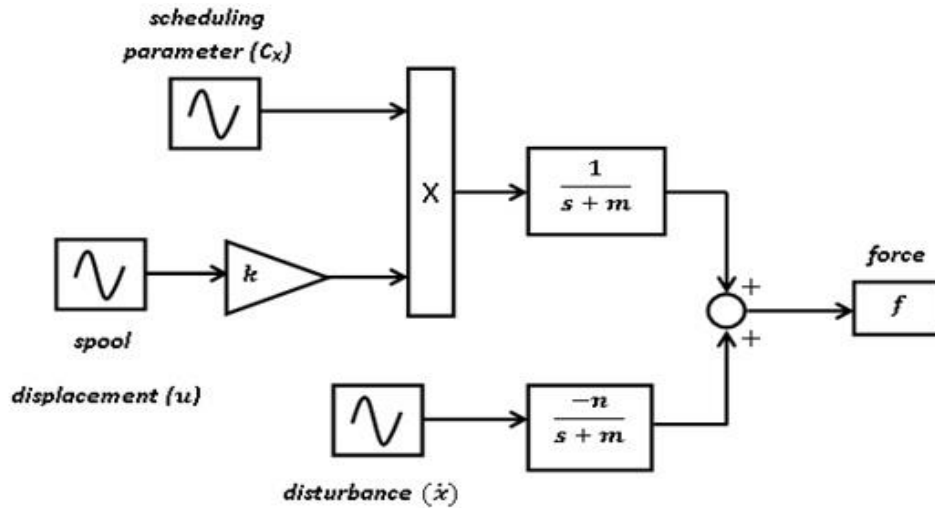

Figure 3. Matlab-Simulink block diagram of the model with gain-scheduling.

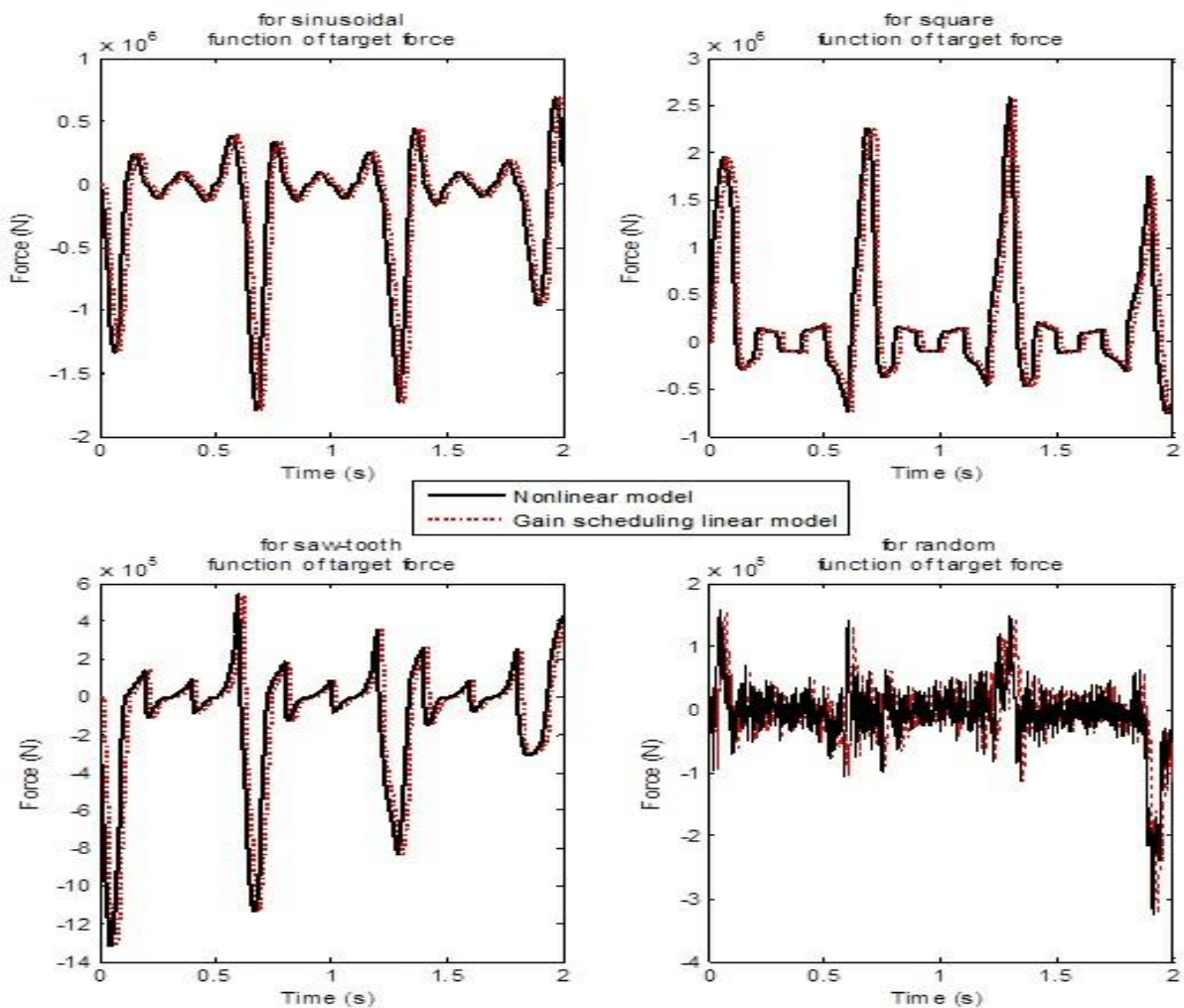

Figure 4. Responses of the models for different inputs.

If k , m and n are substituted in Eq. (4),

$$\dot{f} = k.C_x.u - m.f - n.\dot{x} \quad (8)$$

is obtained. Transfer functions from the inputs of u (spool displacement) and \dot{x} (the relative velocity of the piston) to output f (force) are obtained by using of Laplace transformation. The transfer functions are given in Equation 9 and 10, respectively.

$$\frac{F(s)}{U(s)} = \frac{k.C_x}{s+m} \quad (9)$$

$$\frac{F(s)}{\dot{X}(s)} = \frac{-n}{s+m} \quad (10)$$

The Matlab-Simulink block diagram of the proposed gain scheduling hydraulic actuator model is given in Figure 3. Note that the gain scheduling parameter C_x is a function of actual force and servo valve position and obtained from real system.

3. Simulations

Responses of the nonlinear model and the gain-scheduling linear model for sinusoidal, square, saw-tooth and random functions of the target force are shown in Figure 4. In the simulations, the disturbance input is a sinusoidal function with amplitude of 10 m/s and frequency of 5 rad/s. From these results, it can be seen clearly that the proposed hydraulic actuator model fits the nonlinear model well. It is notable that proposed model gets additional time delay of 0.02 s. Computational load of the operation which the gain scheduling parameter is obtained causes the time delay.

4. Conclusion

In this study, a gain scheduling linear model corresponded with nonlinear model of a electro-hydraulic force actuator system is proposed. Simulation results show that the proposed hydraulic actuator model fits the nonlinear model well. However, proposed model takes a small time delay into the system due to computational extra load stemming from calculating the scheduling parameter. If the time delay partaking of the computational load is considered, proposed model implicitly matches the nonlinear model.

Acknowledgments

This work was supported by the Scientific

Research Unit (BAP) of Inonu University (project number: 2011-33). We gratefully thank to the foundation for the support.

References

- [1] Eposito, A., Fluid Power with Application. Prentice Hall International, Englewood Cliffs Editions Ltd. (1994).
- [2] Garret A. Sohl, James E. Bobrow, Experiments and Simulations On the Nonlinear Control of a Hydraulic System, IEEE Trans. Control Syst. Technol., 7(2), 238–247 (1999).
- [3] Akkaya, A.V., Çetin, Ş. Self-Tuning Fuzzy Logic Control of a Hydraulically Actuating System, Proceedings of 2nd International Conference on Intelligent Knowledge Systems, 154–158 (2005).
- [4] Maneetham, D., Afzulpurkar, N., Modeling, Simulation and Control of High Speed Nonlinear Hydraulic Servo System, World Journal of Modelling and Simulation, 6(1), 27-39 (2010).
- [5] Pfeiffer, F., Deregularization of a smooth system-example hydraulics, Nonlinear Dyn., 47, 219–233 (2007).
- [6] Detiček, E., Kastrevc, M., Design of Lyapunov Based Nonlinear Position Control of Electrohydraulic Servo Systems, Journal of Mechanical Engineering, 62(3), 163-170 (2016).
- [7] Eyres, R., Champneys, A., Nick Lieven, Modelling and Dynamic Response of a Damper With Relief Valve, Nonlinear Dyn., 40, 119–147 (2005).
- [8] Bonchis, A., Corke, P.I., Rye, D.C., Ha, Q. P., Variable Structure Methods In Hydraulic Servo Systems Control, Automatica, 37, 589–595 (2001).
- [9] Kalyoncu, M., Haydim, M. Mathematical Modeling And Fuzzy Logic Based Position Control of an Electro Hydraulic Servo System With Internal Leakage, Mechatronics, Vol:19, No:6, 847–858 (2009).
- [10] Çetin, S., Akkaya, A., V., Simulation and Hybrid Fuzzy-PID Control For Positioning of a Hydraulic System, Nonlinear Dyn, 61(3), 465-476 (2010).
- [11] Onat, C., WGC Based Robust and Gain Scheduling PI Controller Design for Condensing Boilers, Advances in Mechanical Engineering, 1-13 (2014).
- [12] Onat, C., Küçükdemiral, İ.B., Sivrioğlu, S., Yüksek, İ., Cansever, G., LPV Gain-Scheduling Controller Design for a Non-Linear Quarter-Vehicle Active Suspension System, Transactions of the Institute of Measurement & Control, 31(1), 71-95 (2009).
- [13] Onat, C., Küçükdemiral, İ. B., Sivrioğlu, S., Yüksek, İ., LPV Model Based Gain-Scheduling Controller for a Full Vehicle Active Suspension System, Journal of Vibration and Control, 13(11), 1629-1666 (2007).
- [14] Fialho, I. J., Balas, G. J., Design of Nonlinear Controllers for Active Vehicle Suspensions Using

- Parameter-Varying Control Synthesis, Vehicle System Dynamics, 33(5), 351-370 (2000).
- [15] I. J. Fialho, G. J. Balas, Road Adaptive Active Suspension Design Using Linear Parameter-Varying Gain-Scheduling, IEEE Transactions on Control Systems Technology, 10(1), 43-54 (2002).
- [16] Onat, C., Sahin, M., Yaman, Y., Prasad, S., Nema, S., Design of an LPV Based Fractional Controller for the Vibration Suppression of a Smart Beam, International Workshop Smart Materials, Structures & NDT In Aerospace Conference NDT in Canada, Montreal, Quebec, Canada, November (2011).
- [17] Onat, C., Sahin, M., Yaman, Y., Gain-Scheduling H ∞ Control of A Smart Beam with Parameter Varying, Viiiieccomas Thematic Conference On Smart Structures And Materials Smart, 453-463 Madrid, Spain, June, (2017).
- [18] Onat, C., Turan, A., Robust and Gain Scheduling PI Control of Varying Time Delay Systems, ICAIE International Conference on Advances and Innovations in Engineering, 896-89, Elazığ-Turkey, May (2017).

Cem Onat is a graduate of Mersin University, Turkey (BSc, 1999, Mechanical Engineering), Inonu University, Turkey (MSc, 2001, Mechanical Engineering), Yildiz Technical University, Turkey (PhD, 2006, Mechanical Engineering) and Middle East Technical University,

Turkey (Post Doc., 2011, Aeronautical Engineering). Besides, he participated a research in Germany for two months at 2011. His specializations are structural dynamics and experimental analysis of vibrating structures and its control, smart structure applications, active vibration control and wind turbine blade design. He has been an Associate Professor at Inonu University in the Department of Mechanical Engineering since 2009 and is the author of sixteen international scientific papers and conference proceedings.

Mahmut Daskin is a graduate of Inonu University, Turkey (BSc, 2010, Mechanical Engineering), Inonu University, Turkey (MSc, 2013, Mechanical Engineering), Inonu University, Turkey (PhD, starting date 2013, Mechanical Engineering). His specializations are structural dynamics and experimental analysis of vibrating structures and its control, active vibration control. He has been a research assistant in the Department of Mechanical Engineering since 2010. Mahmut DASKIN is the corresponding author.

Abdullah Turan is a graduate of Uludag University, Turkey (BSc, 2010, Mechanical Engineering), Dicle University, Turkey (MSc, 2014, Mechanical Engineering), Inonu University, Turkey (PhD, starting date 2015, Mechanical Engineering). His specializations are structural dynamics and experimental analysis of vibrating structures and its control, active vibration control. He has been a research assistant in the Department of Mechanical Engineering since 2010.

